

6-12

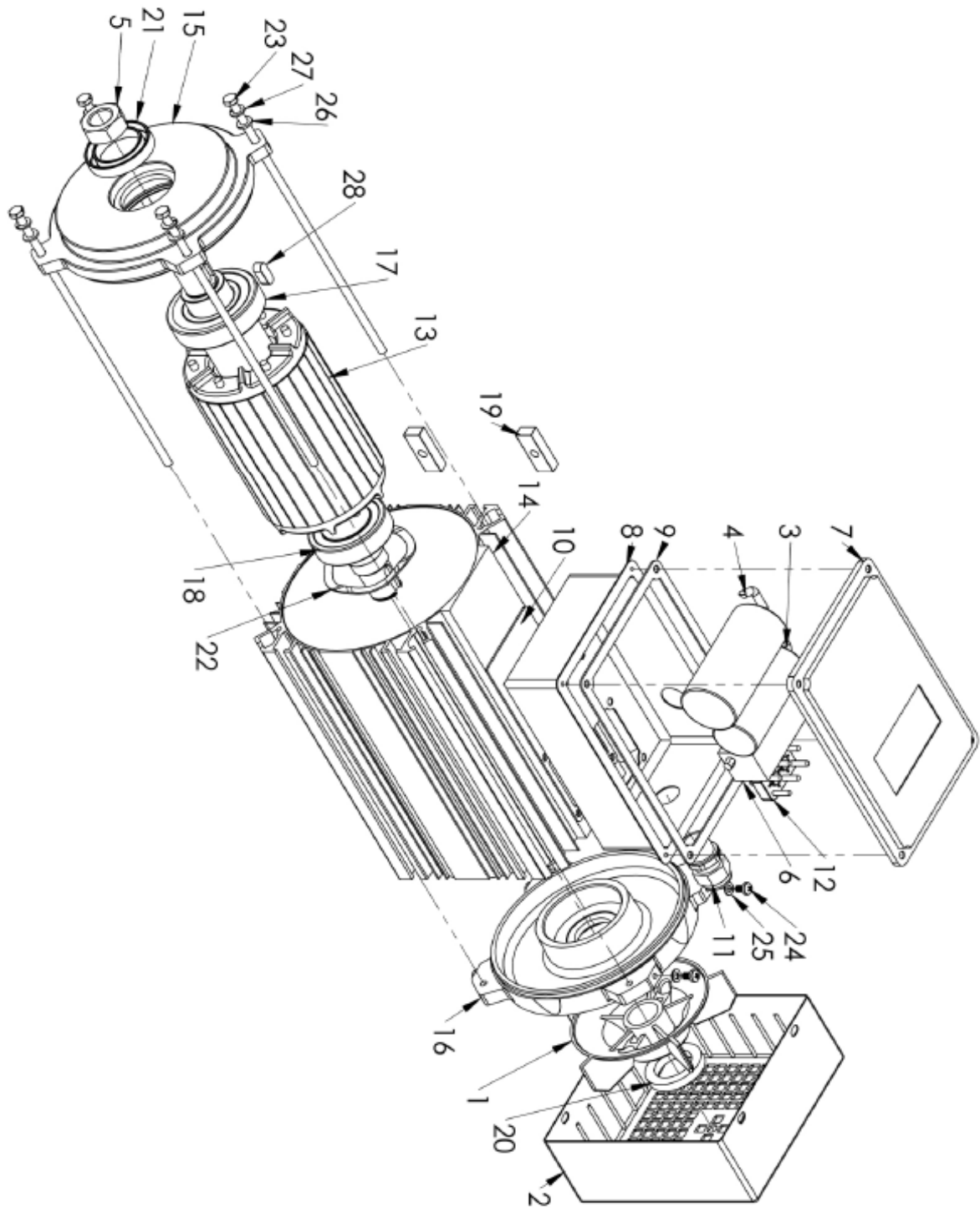

Nr.	Omschrijving	Artikelnummer	Nr.	Omschrijving	Artikelnummer
1	ALUMINIUM FRAME SET	XGZCMS0002201	4.3.1	FILTERSET TBV WATERPOMP	
1.1	ALUMINIUM CONNECTOR RECHTSVOOR	XGZC04020305	4.3.4	INLAATKLEP	
1.2	ALUMINIUM STAAF (KORT)	XGZC04020306	4.10	GAS UNIT 1/4" VROUWELIJK	
1.3	ALUMINIUM CONNECTOR LINKSVOOR	XGZC04020307	4.3.2	AFSLUITRING TBV WATERPOMP	XGZC03020080
1.4	PLAAT	XGZC04021851	4.3.3	VEN TBV WATERPOMP	XGZC03010106
1.5	NOK 975	XGZC04020315	4.4	WATER PLUG MONTAGE	XGZCMS000011
1.6	NOK 1025	XGZC04020335	4.4.1	WATER PLUG	XGZC03010021
1.7	RUBBEREN AFSTANDHOUDER	XGZC03010050	4.4.2	TOUW CONNECTOR	XGZC04020164
1.8	DRAAIRICHTING LABEL (RECHTS)	XGZC06020030	4.4.3	RING	XGZC02030015
1.9	DRAAIRICHTINGLABEL (LINKS)	XGZC06020032	4.4.4	ZELFTAPPENDE SCHROEF	XGZC02010052
1.10	ALUMINIUM STAAF -1110	XGZC04022198	4.4.5	TOUW WATERTANK	XGZC05020001
1.11	RUBBERSTRIP-1190	XGZC03020182	4.5	RING	XGZC02030015
1.12	WATERBAK STEUN GELAST	XGZC04020302	4.6	VEERRING	XGZC02030010
1.13	DRAAIKNOP	XGZC04020333	4.7	KRUISKOPSCHROEF M4X12	XGZC02010038
1.14	ALUMINIUM CONNECTOR RECHTS ACHT	XGZC04020309	4.8	NYLON BORGMOER M4	XGZC02020009
1.15	ZESHOEKIG AFSTANDSSTUK M8	XGZC04020311	4.9	STEKKER MANNELIJK SP2110/P3	XGZC05020004
1.16	VEERRING	XGZC02030006	4.11	SLANGKLEM 16.2	XGZC04020281
1.17	ZESKANTBOUT M8X20	XGZC02010043	5	TRANSPORTWIEL SET	XGZCMS000043
1.18	ZESKANTMOER M8	XGZC02020012	5.1	WIEL D125 D12 W36 MONTAGE	XGZCMS000014
1.19	ZESKANTSCHROEF M8X16	XGZC02010042	5.1.1	TRANSPORTWIEL F125	XGZC03010023
1.20	RING	XGZC02030012	5.1.2	KOGELLAGER	XGZC02050003
1.21	VEERRING	XGZC02030008	5.1.3	BUS Ø12XØ8X36	XGZC04020196
1.22	ISO4762-M10x45	XGZC02010338	5.2	WIELDRAGER	XGZC04020205
1.23	ZESKANTBOUT ISO 4762M 10X30	XGZC02010337	5.3	SLUITRING	XGZC02030017
1.24	RING	XGZC02030021	5.4	ZESKANTMOER M8	XGZC02020012
1.25	NYLON BORGMOER M12	XGZC02020049	5.5	ZESKANTBOUT M8X25	XGZC02010044
1.26	NYLON BORGMOER M5	XGZC02020045	5.6	SCHROEF M8	XGZC02020010
1.27	INBUSBOUT M5X20	XGZC02010062	5.7	ZESKANTBOUT M8X60	XGZC02010053
1.28	WATERGELEIDER GELAST	XGZC040222051	5.8	VEERRING	XGZC02030006
1.29	GELEIDERAIL KUNSTSTOF ZITTING	XGZC03010051	6	ZAAGKOP SET	XGZCMS0001441
1.30	STALEN GELEIDERAIL	XGZC04022200	6.1	ZAAGKOP GELAST	XGZC040211221
1.31	SLUITRING	XGZC02030017	6.2	GLIJLAGER	XGZC02050024
1.32	GROTE RING	XGZC02030013	6.3	SNIJKOP AS	XGZC04020195
1.33	PLAAT	XGZC04021852	6.4	RING	XGZC02030014
1.34	SCHROEF M8	XGZC02020010	6.5	NYLON BORGMOER M20	XGZC02020050
2	POOT SET	XGZCMS000033	6.6	ZESKANTBOUT M12X60	XGZC02010258
2.1	POOT GELAST	XGZC04020299	6.7	NYLON BORGMOER M12	XGZC02020049
2.2	ZESKANTBOUT M12X70	XGZC02010168	6.8	VEERRING	XGZC02030024
2.3	NYLON BORGMOER M12	XGZC02020049	6.9	ZESKANTBOUT M8X20	XGZC02010043
2.4	KUNSTSTOF POOTSTEUN	XGZC03020165	6.10	VEERRING	XGZC02030006
2.5	EINDKAP BUIS Ø25	XGZC03020071	6.11	SLUITRING	XGZC02030017
2.6	RING	XGZC02030021	6.12	2.8KW MOTOR 230V MET M20 LINKSE M	XGZC050101151
2.7	ZESKANTBOUT M8X50	XGZC02010048	6.12.1	VENTILATOR VOOR 2.8KW MOTOR	XGZC03010334
2.8	ZESKANTMOER M8	XGZC02020040	6.12.2	DEKSEL ACHTERKANT 2.8KW MOTOR	XGZC04020905
2.9	NYLON DRUKPLAAT	XGZC03010046	6.12.3	CONDENSATOR 150uF 250vac 50/60 hZ	XGZC05010151
3	TRANSPORT HANDVAT SET	XGZCMS000027	6.12.4	CONDENSATOR X-COUP 40MF	XGZC05010017
3.1	ONDERSTEUNING VOOR TRANSPORTHAN	XGZC04020316	6.12.5	ZESKANTMOER ISO4032-M20LH	XGZC04022006
3.2	HANDVAT BUIS	XGZC04020283	6.12.6	CENTRIFUGAALSCHAKELAAR RE CS-220P	XGZC05010191
3.3	SLUITRING	XGZC02030017	6.12.7	DEKSEL VOOR BEDRADINGSBOX	XGZC03010348
3.4	ZESKANTBOUT M8X30	XGZC02010045	6.12.8	BEDRADINGSDOOS	XGZC03010349
3.5	DOPSLEUTEL-SCHROEF M4X5	XGZC02010071	6.12.9	PAKKING VOOR BEDRADINGSBOXDEKSEL	XGZC03020258
3.6	ZESHOEKIG AFSTANDSSTUK M8	XGZC04020311	6.12.10	PAKKING TUSSEN BEDRADINGSKAST EN M	XGZC03020259
4	WATERBAK SET	XGZCMS000038	6.12.11	KOORDGREEP M20X1,5	XGZC03010350
4.1	WATERBAK	XGZC03010049	6.12.12	KABELAANSLUITBLOK	XGZC05010210
4.2	POMP HOUDER	XGZC04020144	6.13	SCHAKELAAR KOA2	XGZC05010076
4.3+4.	WATER POMP MET MANNELIJKE PLUG	XGZCMS000262	6.14	KRUISKOPSCHROEF M5X45	XGZC02010040
4.3	WATERPOMP 230V 50W	XGZC05010006	6.15	BINNENFLENS	XGZC04022408
	FILTERSET COMPLEET WATERPOMP:	XGZCMS000284	6.16	BUITENFLENS	XGZC04022409

Nr.	Omschrijving	Artikelnummer	Nr.	Omschrijving	Artikelnummer
7	ZAAGTAFEL SET	XGZCMS000222	8.28	SLUITRING	XGZC02030020
7.1	ZAAGTAFEL GELAST	XGZC04022207	8.29	KRUIKOPBOUT M5X16	XGZC02011022
7.2	GELEIDINGSROLSAMENSTEL	XGZCMS000147	8.30	SLUITRING ISO 140HV	XGZC02030016
7.2.1	GELEIDEROL	XGZC04021144	8.31	VEERRING A5	XGZC02030011
7.2.2	DIEPGROEFKOGELLAGER	XGZC02050025	8.32	BUS VOOR LAGER	XGZC04021858
7.2.3	BORGRING	XGZC02030050	8.33	VEER BS400	XGZC04021012
7.3	ZESKANTBOUT M12X50	XGZC02010169	8.34	ZESKANTBOUT M8X25	XGZC02010044
7.4	ZESKANTMOER M12	XGZC02020053	8.35	SLUITRING	XGZC02030017
7.5	ONDERSTEUNENDE ROLSET	XGZCMS000148	8.36	VEERRING	XGZC02030006
7.5.1	ONDERSTEUNENDE ROL	XGZC04021145	8.37	RING	XGZC02030015
7.5.2	DIEPGROEFKOGELLAGER	XGZC02050025	8.38	KABELBRUG	XGZC04020142
7.5.3	BORGRING	XGZC02030050	8.39	VEERRING	XGZC02030010
7.6	BUS	XGZC04021146	8.40	KRUIKOPSCHROEF M4X25	XGZC02010039
7.7	ZESKANTBOUT M8X12	XGZC02010121	8.41	ZESKANTBOUT M12X25	XGZC02010259
7.8	ZESKANTSCHROEF M8X16	XGZC02010042	8.42	IGUS LAGER	XGZC02050020
7.9	BUS	XGZC04021147	9	ZAAGKAPBESCHERMING	XGZCMS000232
7.10	ANIT KANTELWIEL SET	XGZCMS000149	9.1	ZAAGKAP GELAST	XGZC04022411
7.10.1	ANTI KANTEL WIEL	XGZC04021148	9.2	Y-VERDELER GELAST	XGZC04022412
7.10.2	KOGELLAGER	XGZC02050002	9.3	STICKER MET PIJL	XGZC06020026
7.10.3	BORGVEER	XGZC02030051	9.4	WATERKRAAN 1/4 '	XGZC02070002
7.11	ZESKANTBOUT M8X35	XGZC02010090	9.5	REDUCERENDE NIPEL	XGZC02070001
7.12	KALIBRATIE PLAAT	XGZC04021116	9.6	SLANGKLEM 16.2	XGZC04020281
7.13	DUWHANDVAT SET	XGZCMS000188	9.7	BRONWATERLEIDING	XGZC03010162
7.13.1	DUWHANDVAT	XGZC04021878	9.8	RUBBER VOOR HET BLOKKEREN VAN WA	XGZC03020109
7.13.2	PLASTIC HENDEL	XGZC03010018	9.9	RUBBEREN VASTE PLAAT	XGZC04021108
7.13.3	EINDKAP BUIS Ø20	XGZC03010027	9.10	KRUIKOPSCHROEF M4X12	XGZC02010038
7.14	ZESKANTBOUT M8X35	XGZC02010118	9.11	BESCHERMSTICKER	XGZC06020022
7.15	VEERRING	XGZC02030006	9.12	VASTE PLAAT	XGZC04022413
7.16	SLUITRING	XGZC02030017	9.13	INBUSBOUT M10X70	XGZC02010194
7.17	DRIJFSTANG	XGZC04021143	9.14	RING	XGZC02030012
8	DRAAGARM SET	XGZCMS0002311	9.15	NYLON BORGMOER M10	XGZC02020008
8.1	VERTICALE ARM GELAST	XGZC040219131	9.16	ZESKANTBOUT M8X25	XGZC02010044
8.2	LAGER	XGZC02050035	9.17	SLUITRING	XGZC02030017
8.3	ZESKANTBOUT M12X60	XGZC02010258	9.18	VEERRING	XGZC02030006
8.4	NYLON BORGMOER M12	XGZC02020049	9.19	ZESKANTMOER M8	XGZC02020012
8.5	OOGSCHROEVEN	XGZC02050019	9.20	FLENSMOER M10	XGZC02020070
8.6	DRIJFSTANG	XGZC04021137	9.21	WATER AANSLUITING ELLEBOOG	XGZC04022021
8.7	ZESKANTMOER M12	XGZC02020053	9.22	GAS UNIT 1/4" VROUWELIJK	XGZC02070003
8.8	RONDE DOP F30	XGZC03020112	10	SET LASERFRAME	XGZCMS0002211
8.9	RING	XGZC02030012	10.1	LASERFRAME	XGZC040222061
8.10	VEERRING	XGZC02030008	10.2	LASERSET	XGZCTS000103
8.11	BOUT M10X20	XGZC02010171	10.2.1	LASER BALL_L	XGZC03010214
8.12	PLAT STAAL	XGZC04021853	10.2.2	LASER BALL_R	XGZC03010215
8.13	PLAT STAAL	XGZC04021854	10.2.3	LASERLAMP 9X21 -110HOEK	XGZC05010070
8.14	ROTTERENDE ARM GELAST	XGZC040218551	10.2.4	LASERBAL HOOFD COVER	XGZC03010216
8.15	VEERRING	XGZC02030024	10.2.5	HEX. INBUSBOUT M4X10	XGZC02010255
8.16	OOGBOUT M12x60	XGZC02010286	10.2.6	ZESKANTMOER M4	XGZC02020015
8.17	DIEPTE-AANPASSINGSBALK	XGZC04021882	10.2.7	HEX. INBUSBOUT M4X25	XGZC02010256
8.18	ZESKANTBOUT M12X30	XGZC02010218	10.2.8	LASERBAL ZIJKANT COVER	XGZC03010217
8.19	RING	XGZC02030021	10.3	VEILIGHEIDSTICKER	XGZC06020180
8.20	NYLON SLOT DUNNE MOER M12	XGZC02020054	10.4	VEILIGHEIDSTICKER	XGZC06020181
8.21	GROTE RING	XGZC02030049	10.5	ZESKANTBOUT M8X12	XGZC02010121
8.22	HANDVAT	XGZC03010159	10.6	VEERRING	XGZC02030006
8.23	ONDERSTEUNING SPATSCHERM	XGZC04021912	10.7	SLUITRING	XGZC02030017
8.24	SPATSCHERM FRAME	XGZC03020159	10.8	HEX. INBUSBOUT M4X25	XGZC02010256
8.25	PLAAT	XGZC04021857	11	GEREEDSCHAPSHOUDER EN GEREEDSCHAP	XGZCMS000243
8.26	ZESKANTBOUT M6X12	XGZC02010184	11.1	HOUDER VOOR GEREEDSCHAP	XGZC04022487
8.27	VEERRING	XGZC02030019	11.2	SLEUTEL 13 MM	XGZC04020163

Nr.	Omschrijving	Artikelnummer
11.3	SLEUTEL 30 MM	XGZC04020162
11.4	RING	XGZC02030015
11.5	VEERRING	XGZC02030010
11.6	KRUISPAN ZESKANTBOUT M4X10	XGZC02010180
11.7	SLEUTEL 17MM	XGZC04020589
11.8	INBUSSLEUTEL 3MM	XGZC04022208
12	HIJSOOG RECHTHOEKIG SET 2	XGZCMS000258
12.1	MACHINE HIJSOOG RECHTHOEKIG	XGZC04022632
12.2	ZESKANTBOUT M8X25	XGZC02010044
12.3	ZESKANTMOER M8	XGZC02020040
12.4	GROTE RING	XGZC02030013
12.5	VERGRENDELPLAAT	XGZC04022905
12.6	AFSTANDSHOUDER	XGZC04022906
13	FRAME VERSTERKENDE MONTAGE	XGZCMS000285
13.1	VERSTEVIINGSSTUK	XGZC04023036
13.2	SLUITRING	XGZC02030017
13.3	VEERRING DIN 127 - A8	XGZC02030006
13.4	ZESKANTSCHROEF M8X16	XGZC02010042
13.5	ZESHOEKIG AFSTANDSSTUK M8	XGZC04020311
14	ASSEMBLAGE STALEN GELEIDER	XGZCMS000287
14.1	STALEN GELEIDER	XGZC04023132
14.2	GRIPKNOP STER M10x25	XGZC03010145
	STROOMKABEL 230V GC/GP/GT/BEX SER	XGZC05010069

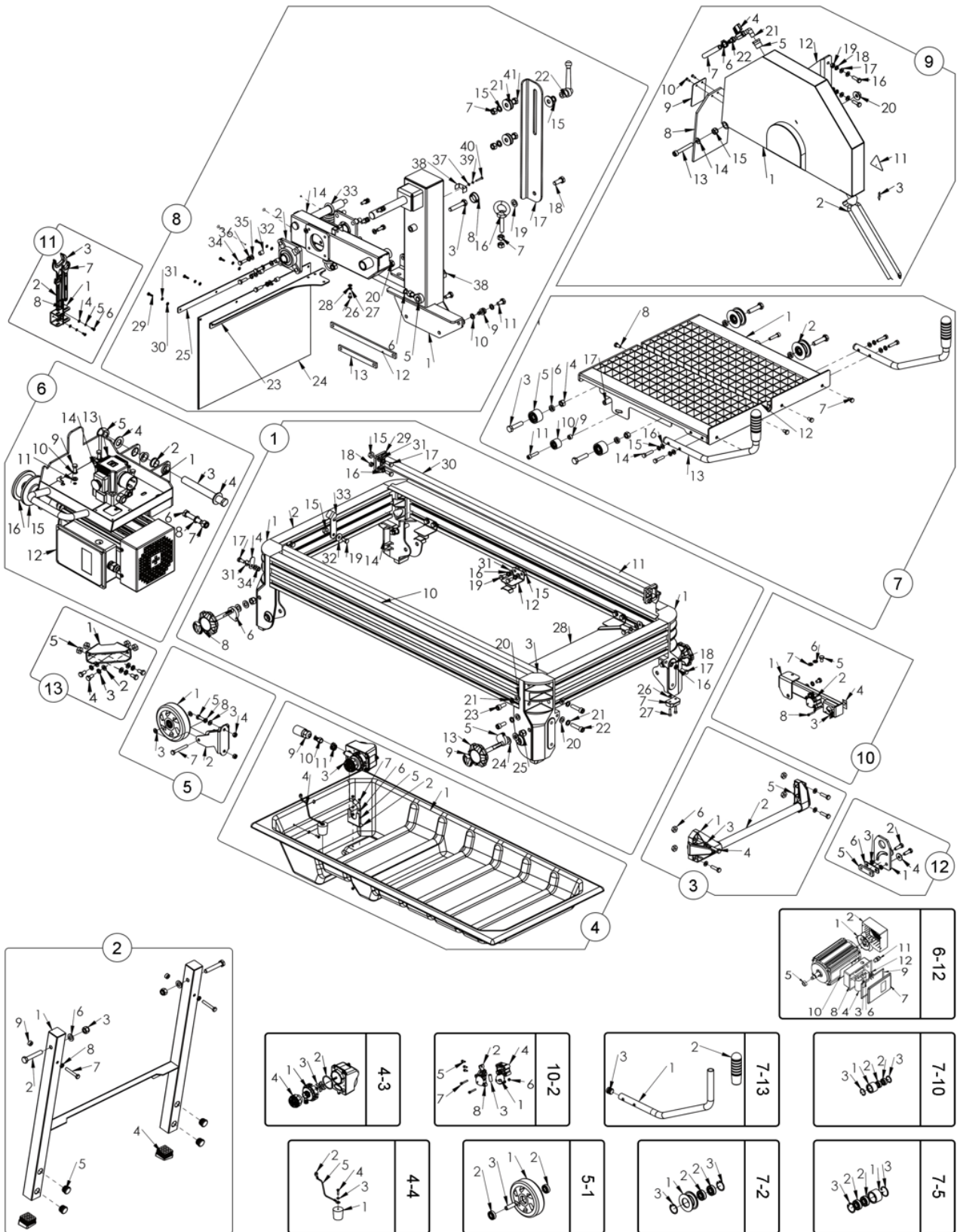

Nr.	Omschrijving	Artikelnummer	Nr.	Omschrijving	Artikelnummer
1	ALUMINIUM FRAME SET	XGZCMS0002201	4.3.1	FILTERSET TBV WATERPOMP	
1.1	ALUMINIUM CONNECTOR RECHTSVOOR	XGZC04020305	4.3.4	INLAATKLEP	
1.2	ALUMINIUM STAAF (KORT)	XGZC04020306	4.10	GAS UNIT 1/4" VROUWELIJK	
1.3	ALUMINIUM CONNECTOR LINKSVOOR	XGZC04020307	4.3.2	AFSLUITRING TBV WATERPOMP	XGZC03020080
1.4	PLAAT	XGZC04021851	4.3.3	VEN TBV WATERPOMP	XGZC03010106
1.5	NOK 975	XGZC04020315	4.4	WATER PLUG MONTAGE	XGZCMS000011
1.6	NOK 1025	XGZC04020335	4.4.1	WATER PLUG	XGZC03010021
1.7	RUBBEREN AFSTANDHOUDER	XGZC03010050	4.4.2	TOUW CONNECTOR	XGZC04020164
1.8	DRAAIRICHTING LABEL (RECHTS)	XGZC06020030	4.4.3	RING	XGZC02030015
1.9	DRAAIRICHTINGLABEL (LINKS)	XGZC06020032	4.4.4	ZELFTAPPENDE SCHROEF	XGZC02010052
1.10	ALUMINIUM STAAF -1110	XGZC04022198	4.4.5	TOUW WATERTANK	XGZC05020001
1.11	RUBBERSTRIP-1190	XGZC03020182	4.5	RING	XGZC02030015
1.12	WATERBAK STEUN GELAST	XGZC04020302	4.6	VEERING	XGZC02030010
1.13	DRAAIKNOP	XGZC04020333	4.7	KRUISKOPSCHROEF M4X12	XGZC02010038
1.14	ALUMINIUM CONNECTOR RECHTS ACHT	XGZC04020309	4.8	NYLON BORGMOER M4	XGZC02020009
1.15	ZESHOEKIG AFSTANDSSTUK M8	XGZC04020311	4.9	STEKKER MANNELIJK SP2110/P3	XGZC05020004
1.16	VEERING	XGZC02030006	4.11	SLANGKLEM 16.2	XGZC04020281
1.17	ZESKANTBOUT M8X20	XGZC02010043	5	TRANSPORTWIEL SET	XGZCMS000043
1.18	ZESKANTMOER M8	XGZC02020012	5.1	WIEL D125 D12 W36 MONTAGE	XGZCMS000014
1.19	ZESKANTSCHROEF M8X16	XGZC02010042	5.1.1	TRANSPORTWIEL F125	XGZC03010023
1.20	RING	XGZC02030012	5.1.2	KOGELLAGER	XGZC02050003
1.21	VEERING	XGZC02030008	5.1.3	BUS Ø12XØ8X36	XGZC04020196
1.22	ISO4762-M10x45	XGZC02010338	5.2	WIELDRAGER	XGZC04020205
1.23	ZESKANTBOUT ISO 4762M 10X30	XGZC02010337	5.3	SLUITRING	XGZC02030017
1.24	RING	XGZC02030021	5.4	ZESKANTMOER M8	XGZC02020012
1.25	NYLON BORGMOER M12	XGZC02020049	5.5	ZESKANTBOUT M8X25	XGZC02010044
1.26	NYLON BORGMOER M5	XGZC02020045	5.6	SCHROEF M8	XGZC02020010
1.27	INBUSBOUT M5X20	XGZC02010062	5.7	ZESKANTBOUT M8X60	XGZC02010053
1.28	WATERGELEIDER GELAST	XGZC040222051	5.8	VEERING	XGZC02030006
1.29	GELEIDERAIL KUNSTSTOF ZITTING	XGZC03010051	6	ZAAGKOP SET	XGZCMS0001441
1.30	STALEN GELEIDERAIL	XGZC04022200	6.1	ZAAGKOP GELAST	XGZC040211221
1.31	SLUITRING	XGZC02030017	6.2	GLIJLAGER	XGZC02050024
1.32	GROTE RING	XGZC02030013	6.3	SNIJKOP AS	XGZC04020195
1.33	PLAAT	XGZC04021852	6.4	RING	XGZC02030014
1.34	SCHROEF M8	XGZC02020010	6.5	NYLON BORGMOER M20	XGZC02020050
2	POOT SET	XGZCMS000033	6.6	ZESKANTBOUT M12X60	XGZC02010258
2.1	POOT GELAST	XGZC04020299	6.7	NYLON BORGMOER M12	XGZC02020049
2.2	ZESKANTBOUT M12X70	XGZC02010168	6.8	VEERING	XGZC02030024
2.3	NYLON BORGMOER M12	XGZC02020049	6.9	ZESKANTBOUT M8X20	XGZC02010043
2.4	KUNSTSTOF POOTSTEUN	XGZC03020165	6.10	VEERING	XGZC02030006
2.5	EINDKAP BUIS Ø25	XGZC03020071	6.11	SLUITRING	XGZC02030017
2.6	RING	XGZC02030021	6.12	MOTOR 3.0KW 400V MET M20 BOUT	XGZC050101221
2.7	ZESKANTBOUT M8X50	XGZC02010048	6.12.1	VENTILATOR VOOR 2.8KW MOTOR	XGZC03010334
2.8	ZESKANTMOER M8	XGZC02020040	6.12.2	DEKSEL ACHTERKANT 2.8KW MOTOR	XGZC04020905
2.9	NYLON DRUKPLAAT	XGZC03010046	6.12.3	N/A IN DIT MODEL	
3	TRANSPORT HANDVAT SET	XGZCMS000027	6.12.4	N/A IN DIT MODEL	
3.1	ONDERSTEUNING VOOR TRANSPORTHAN	XGZC04020316	6.12.5	ZESKANTMOER ISO4032-M20LH	XGZC04022006
3.2	HANDVAT BUIS	XGZC04020283	6.12.6	N/A IN DIT MODEL	
3.3	SLUITRING	XGZC02030017	6.12.7	N/A IN DIT MODEL	
3.4	ZESKANTBOUT M8X30	XGZC02010045	6.12.8	N/A IN DIT MODEL	
3.5	DOPSLEUTEL-SCHROEF M4X5	XGZC02010071	6.12.9	N/A IN DIT MODEL	
3.6	ZESHOEKIG AFSTANDSSTUK M8	XGZC04020311	6.12.10	N/A IN DIT MODEL	
4	WATERBAK SET	XGZCMS000038	6.12.11	N/A IN DIT MODEL	
4.1	WATERBAK	XGZC03010049	6.12.12	N/A IN DIT MODEL	
4.2	POMP HOUDER	XGZC04020144	6.13	SCHAKELAAR MET LASER 400V -1M	XGZC05010117
4.3+4.	WATER POMP MET MANNELIJKE PLUG	XGZCMS000262	6.14	KRUISKOPSCHROEF M5X45	XGZC02010040
4.3	WATERPOMP 230V 50W	XGZC05010006	6.15	BINNENFLENS	XGZC04022408
	FILTERSET COMPLEET WATERPOMP:	XGZCMS000284	6.16	BUITENFLENS	XGZC04022409

Nr.	Omschrijving	Artikelnummer	Nr.	Omschrijving	Artikelnummer
7	ZAAGTAFEL SET	XGZCMS000222	8.27	VEERRING	XGZC02030019
7.1	ZAAGTAFEL GELAST	XGZC04022207	8.28	SLUITRING	XGZC02030020
7.2	GELEIDINGSROLSAMENSTEL	XGZCMS000147	8.29	KRUIKOPBOUT M5X16	XGZC02011022
7.2.1	GELEIDEROL	XGZC04021144	8.30	SLUITRING ISO 140HV	XGZC02030016
7.2.2	DIEPGROEFKOGELLAGER	XGZC02050025	8.31	VEERRING A5	XGZC02030011
7.2.3	BORGRING	XGZC02030050	8.32	BUS VOOR LAGER	XGZC04021858
7.3	ZESKANTBOUT M12X50	XGZC02010169	8.33	VEER BS400	XGZC04021012
7.4	ZESKANTMOER M12	XGZC02020053	8.34	ZESKANTBOUT M8X25	XGZC02010044
7.5	ONDERSTEUNENDE ROLSET	XGZCMS000148	8.35	SLUITRING	XGZC02030017
7.5.1	ONDERSTEUNENDE ROL	XGZC04021145	8.36	VEERRING	XGZC02030006
7.5.2	DIEPGROEFKOGELLAGER	XGZC02050025	8.37	RING	XGZC02030015
7.5.3	BORGRING	XGZC02030050	8.38	KABELBRUG	XGZC04020142
7.5	ONDERSTEUNENDE ROLSET	XGZCMS000148	8.39	VEERRING	XGZC02030010
7.6	BUS	XGZC04021146	8.40	KRUIKOPSCHROEF M4X25	XGZC02010039
7.7	ZESKANTBOUT M8X12	XGZC02010121	8.41	ZESKANTBOUT M12X25	XGZC02010259
7.8	ZESKANTSCHROEF M8X16	XGZC02010042	8.42	IGUS LAGER	XGZC02050020
7.9	BUS	XGZC04021147	9	ZAAGKAPBESCHERMING	XGZCMS000232
7.10	ANIT KANTELWIEL SET	XGZCMS000149	9.1	ZAAGKAP GELAST	XGZC04022411
7.10.1	ANTI KANTEL WIEL	XGZC04021148	9.2	Y-VERDELER GELAST	XGZC04022412
7.10.2	KOGELLAGER	XGZC02050002	9.3	STICKER MET PIJL	XGZC06020026
7.10.3	BORGVEER	XGZC02030051	9.4	WATERKRAAN 1/4 '	XGZC02070002
7.11	ZESKANTBOUT M8X35	XGZC02010090	9.5	REDUCERENDE NIPEL	XGZC02070001
7.12	KALIBRATIE PLAAT	XGZC04021116	9.6	SLANGKLEM 16.2	XGZC04020281
7.13	DUWHANDVAT SET	XGZCMS000188	9.7	BRONWATERLEIDING	XGZC03010162
7.13.1	DUWHANDVAT	XGZC04021878	9.8	RUBBER VOOR HET BLOKKEREN VAN WA	XGZC03020109
7.13.2	PLASTIC HENDEL	XGZC03010018	9.9	RUBBEREN VASTE PLAAT	XGZC04021108
7.13.3	EINDKAP BUIS Ø20	XGZC03010027	9.10	KRUIKOPSCHROEF M4X12	XGZC02010038
7.14	ZESKANTBOUT M8X35	XGZC02010118	9.11	BESCHERMSTICKER	XGZC06020022
7.15	VEERRING	XGZC02030006	9.12	VASTE PLAAT	XGZC04022413
7.16	SLUITRING	XGZC02030017	9.13	INBUSBOUT M10X70	XGZC02010194
7.17	DRIJFSTANG	XGZC04021143	9.14	RING	XGZC02030012
8	DRAAGARM SET	XGZCMS0002311	9.15	NYLON BORGMOER M10	XGZC02020008
8.1	VERTICALE ARM GELAST	XGZC040219131	9.16	ZESKANTBOUT M8X25	XGZC02010044
8.2	LAGER	XGZC02050035	9.17	SLUITRING	XGZC02030017
8.3	ZESKANTBOUT M12X60	XGZC02010258	9.18	VEERRING	XGZC02030006
8.4	NYLON BORGMOER M12	XGZC02020049	9.19	ZESKANTMOER M8	XGZC02020012
8.5	OOGSCHROEFEN	XGZC02050019	9.20	FLENSMOER M10	XGZC02020070
8.6	DRIJFSTANG	XGZC04021137	9.21	WATER AANSLUITING ELLEBOOG	XGZC04022021
8.7	ZESKANTMOER M12	XGZC02020053	9.22	GAS UNIT 1/4" VROUWELIJK	XGZC02070003
8.8	RONDE DOP F30	XGZC03020112	10	SET LASERFRAME	XGZCMS0002211
8.9	RING	XGZC02030012	10.1	LASERFRAME	XGZC040222061
8.10	VEERRING	XGZC02030008	10.2	LASERSET	XGZCTS000103
8.11	BOUT M10X20	XGZC02010171	10.2.1	LASER BALL_L	XGZC03010214
8.12	PLAT STAAL	XGZC04021853	10.2.2	LASER BALL_R	XGZC03010215
8.13	PLAT STAAL	XGZC04021854	10.2.3	LASERLAMP 9X21 -110HOEK	XGZC05010070
8.14	ROTTERENDE ARM GELAST	XGZC040218551	10.2.4	LASERBAL HOOFD COVER	XGZC03010216
8.15	VEERRING	XGZC02030024	10.2.5	HEX. INBUSBOUT M4X10	XGZC02010255
8.16	OOGBOUT M12x60	XGZC02010286	10.2.6	ZESKANTMOER M4	XGZC02020015
8.17	DIEPTE-AANPASSINGSBALK	XGZC04021882	10.2.7	HEX. INBUSBOUT M4X25	XGZC02010256
8.18	ZESKANTBOUT M12X30	XGZC02010218	10.2.8	LASERBAL ZIJKANT COVER	XGZC03010217
8.19	RING	XGZC02030021	10.3	VEILIGHEIDSTICKER	XGZC06020180
8.20	NYLON SLOT DUNNE MOER M12	XGZC02020054	10.4	VEILIGHEIDSTICKER	XGZC06020181
8.21	GROTE RING	XGZC02030049	10.5	ZESKANTBOUT M8X12	XGZC02010121
8.22	HANDVAT	XGZC03010159	10.6	VEERRING	XGZC02030006
8.23	ONDERSTEUNING SPATSCHERM	XGZC04021912	10.7	SLUITRING	XGZC02030017
8.24	SPATSCHERM FRAME	XGZC03020159	10.8	HEX. INBUSBOUT M4X25	XGZC02010256
8.25	PLAAT	XGZC04021857	11	GEREEDSCHAPSHOUDER EN GEREEDSCH	XGZCMS000243
8.26	ZESKANTBOUT M6X12	XGZC02010184	11.1	HOUDER VOOR GEREEDSCHAP	XGZC04022487

Nr.	Omschrijving	Artikelnummer
11.2	SLEUTEL 13 MM	XGZC04020163
11.3	SLEUTEL 30 MM	XGZC04020162
11.4	RING	XGZC02030015
11.5	VEERRING	XGZC02030010
11.6	KRUISPAN ZESKANTBOUT M4X10	XGZC02010180
11.7	SLEUTEL 17MM	XGZC04020589
11.8	INBUSSLEUTEL 3MM	XGZC04022208
12	HIJSOOG RECHTHOEKIG SET 2	XGZCMS000258
12.1	MACHINE HIJSOOG RECHTHOEKIG	XGZC04022632
12.2	ZESKANTBOUT M8X25	XGZC02010044
12.3	ZESKANTMOER M8	XGZC02020040
12.4	GROTE RING	XGZC02030013
12.5	VERGRENDELPLAAT	XGZC04022905
12.6	AFSTANDSHOUDER	XGZC04022906
13	FRAME VERSTERKENDE MONTAGE	XGZCMS000285
13.1	VERSTEVIINGSSTUK	XGZC04023036
13.2	SLUITRING	XGZC02030017
13.3	VEERRING DIN 127 - A8	XGZC02030006
13.4	ZESKANTSCHROEF M8X16	XGZC02010042
13.5	ZESHOEKIG AFSTANDSSTUK M8	XGZC04020311
	STROOMKABEL 400V GP/GT SERIE	XGZC05020039